

FEZZA
AUDIO

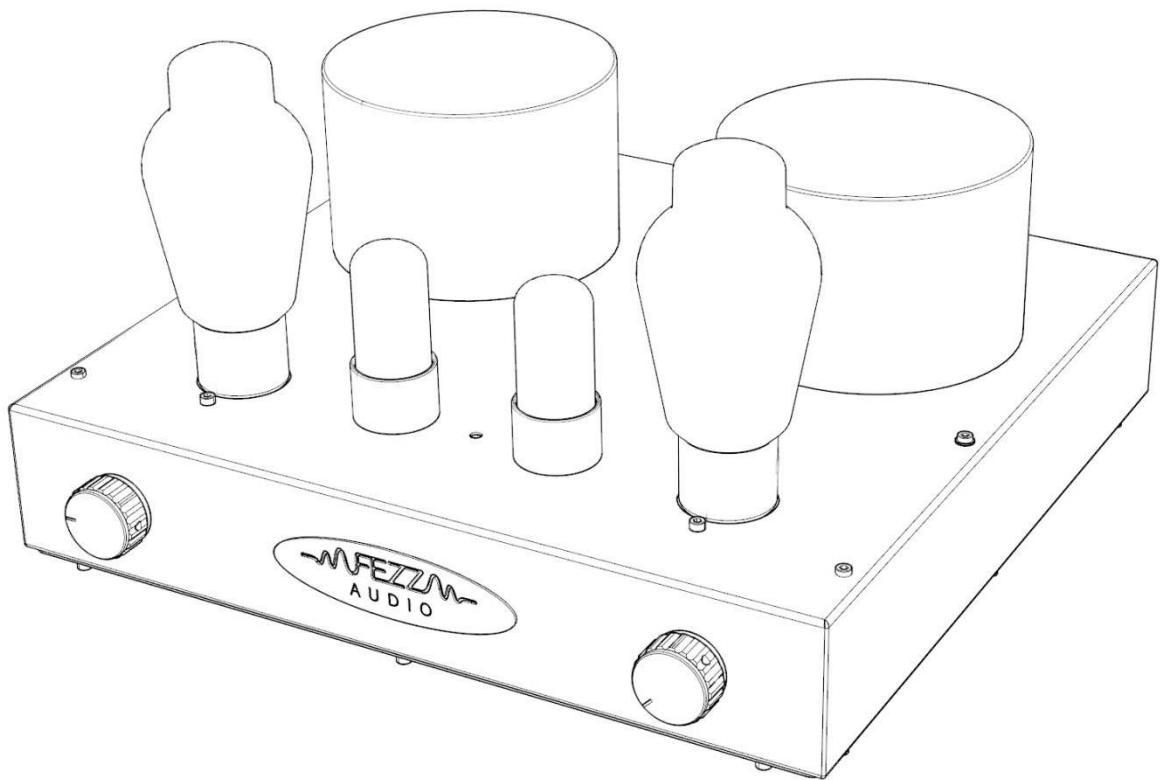

Mira Ceti

USER'S MANUAL

SAFETY TIPS _____



In order to obtain the highest possible sound reproduction quality and for the sake of your own safety, please kindly refer to the following safety guidelines and please adhere to them:

- Never place the Fezz Audio Mira Ceti amplifier near heat sources, such as radiators, heaters or direct sunlight. Ensure adequate ventilation and airflow.
- We also warn against exposure of the amplifier to conditions such as very low temperatures and/or high humidity.
- During normal operation, the vacuum tubes radiate significant amounts of heat - there is a risk of burns
- The amplifier should be plugged directly into a wall socket. If you must use an extension cord, please make sure that it has load parameters sufficient to ensure proper handling of current delivery to the device.
- When cleaning, always disconnect the Mira Ceti from the power source. Use a dry, soft cloth. Do not use water or cleaning agents.
- If your amplifier starts to misbehave or to work incorrectly, if it's temperature gets too high or you start feeling smoke - immediately disconnect the device from the mains.
- Due to the risk of exposure to high voltages - please do not open the lid of the amplifier. **ATTENTION:** This warning remains in force also in a situation where the device is already disconnected from the wall outlet.
- Always replace fuses in accordance with the original, intended specification.
- Do not make repairs on your own, or adjustments beyond those as described in this manual. Execution of any unauthorized repairs or modifications of the device result in a loss of warranty.

TABLE OF CONTENTS _____

SAFETY TIPS _____ **2**

INTRODUCTION _____ **4**

The Tube Amplifier

INSTALLATION OF THE DEVICE _____ **5**

Unpacking

Contents of the package

Description of the elements of the amplifier

Installation of the vacuum tubes

Where to place your amplifier

INTERCONNECTIONS _____ **8**

Hook-up of the power supply cord

Hook-up of the signal sources

Hook-up of the speakers

STANDARD AND OPTIONAL EQUIPMENT _____ **10**

Vacuum tubes protective cage

Remote control

HT (pre-in) input

FIRST POWER-UP AND GETTING STARTED _____ **11**

ADJUSTMENT AND CONTROL OF THE BIAS CURRENTS _____ **12**

REPLACEMENT OF THE VACUUM TUBES _____ **12**

Vacuum tube replacement procedure

"BURNING-IN" THE AMPLIFIER _____ **12**

TROUBLE-SHOOTING GUIDE _____ **13**

TECHNICAL DATA _____ **14**

LIMITED WARRANTY CONDITIONS _____ **15**

INTRODUCTION

Thank you for your trust and for choosing the Fezz Audio Mira Ceti amplifier.

Mira Ceti The World's only Single-Ended tube amplifier, the construction of which is based on toroidal speaker output transformers. Mira Ceti is characterized by an outstanding, full, saturated midtone, by dynamics and a solid bass. Tonal character is covered with a sensual tube mist which provides excellent reproduction of blues, jazz and classic rock.

THE TUBE AMPLIFIER

Many of us, when looking upon audio amplifiers of decades ago, keep repeating a slogan, like a mantra: "Such things are not manufactured anymore". When we finally manage to acquire such a amplifier, we treat it in a very unique way. We look for the best possible location to present it, we adore the moment that we switch it on and we shall certainly not fail to mention in passing about this new "treasure" of ours to any of our visiting guests. Whatever we do is all underlined by a great feeling of fondness to those times long past. Why is this happening? The most likely reason is that it is a vacuum tube amplifier. An amplifier with a specific warmth to its sound, with a natural ambience, timber. We also do know that the 'Big Names' have created their memorable music albums using vacuum tubes. When one explores this topic in depth, it turns out that many a prominent musician, till this present day, plays back music and creates music using solely analog amplifiers, and they justify their decision with just a few words: "The vacuum tube simply sounds better, it has a soul and an ambience".

Once that we purchase such an amplifier, set it up, hook it up, a kind of hesitance kicks in ... "Gee, this equipment is 40 years old". Will it continue to be reliable? We are aware that there is contemporary production of vacuum tube amplifiers out there, but these amplifiers are very expensive. Thus, in praxis, they are exclusively destined for the audiophile circles.

And it is at this very point where the unique offering of Fezz Audio comes into play. A unique vacuum tube sound, made available at a price point similar to a new, "transistor" based device as sourced from a market.

INSTALATION OF THE DEVICE _____

UNPACKING

Please kindly check if the packaging of the Mira Ceti amplifier has not been damaged during transit. If you find any damages, please immediately contact your dealer. Remove the amplifier and accessories from the packaging. Make sure that the content is not damaged.



Do not connect the device to the power supply if it has visible signs of damage on it.

Please do not dispose of the original packaging, so as to facilitate possible shipment of the device in the future.

CONTENTS OF THE PACKAGE

The package should contain:

- The Fezz Audio Mira Ceti vacuum tube amplifier
- Vacuum tubes of type 300b EHG (gold), by Electro-Harmonix – 2 pcs.
- Vacuum tubes of type 6sn7, by Electro-Harmonix – 2 pcs.
- A power cord
- Vacuum tube protective cage
- A Users Manual
- Optional: remote control

DESCRIPTION OF THE ELEMENTS OF THE AMPLIFIER

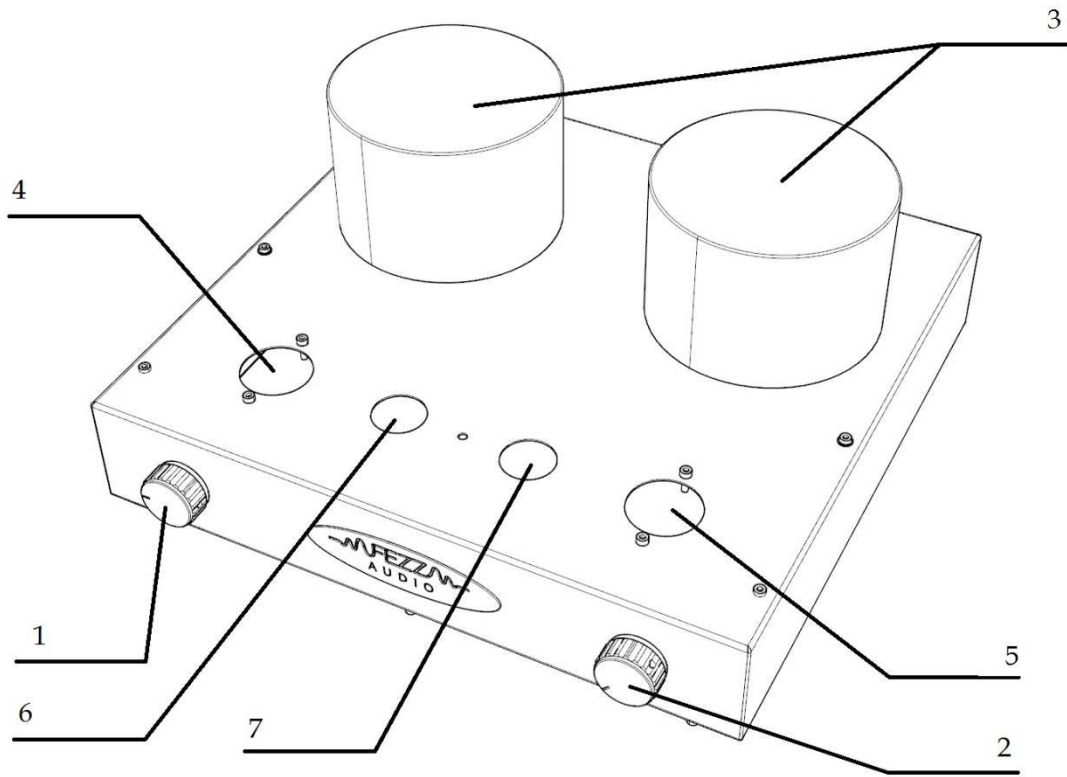

- 1) Volume control
- 2) Input source selector
- 3) The housings for the output transformers
- 4) Left channel power vacuum tube (300b) socket
- 5) Right channel power vacuum tube (300b) socket
- 6) Left channel driver vacuum tube (6sn7) socket
- 7) Right channel driver vacuum tube (6sn7) socket

INSTALLATION OF THE VACUUM TUBES

Place the Mira Ceti amplifier on a stable surface. Carefully remove the vacuum tubes from their packaging and install them in the appropriate sockets, as show on page 6.

The pins in the base of each of the vacuum tubes are “coded”, and this has the result that the insertion of the vacuum tube into the socket is possible only in one correct and appropriate orientation. If, whilst inserting the vacuum tube you sense resistance, and you can not push the tube into the socket, please check the orientation of its pins, rotate the tube to the correct position and try again.



WARNING ! Excessive force may damage the socket and/or the pins of the vacuum tube.

WHERE TO PLACE YOUR AMPLIFIER

Due to the presence of high temperatures during normal operation of the vacuum tubes, the location that you pick to place your amplifier should ensure ample ventilation, a free flow of air.

Please maintain at least 10 cm clearance between the housing of the amplifier, together with the vacuum tubes, and other devices or elements of the interior.

The sound quality may be degraded as a result of vibrations. Therefore we recommended to place the amplifier on a flat and stable surface.



ATTENTION - Never place the Fezz Audio Mira Ceti amplifier in the vicinity of sources that produce large amounts of heat.

INTERCONNECTIONS

The figure above shows the rear panel view of the Fezz Audio Mira Ceti vacuum tube amplifier, together with a description of the inputs and outputs allowing for connection of the other elements of your audio system.

Any and all connections must be made whilst the device is disconnected from the mains power supply. Before making any such connections, make sure that the amplifier is switched off.

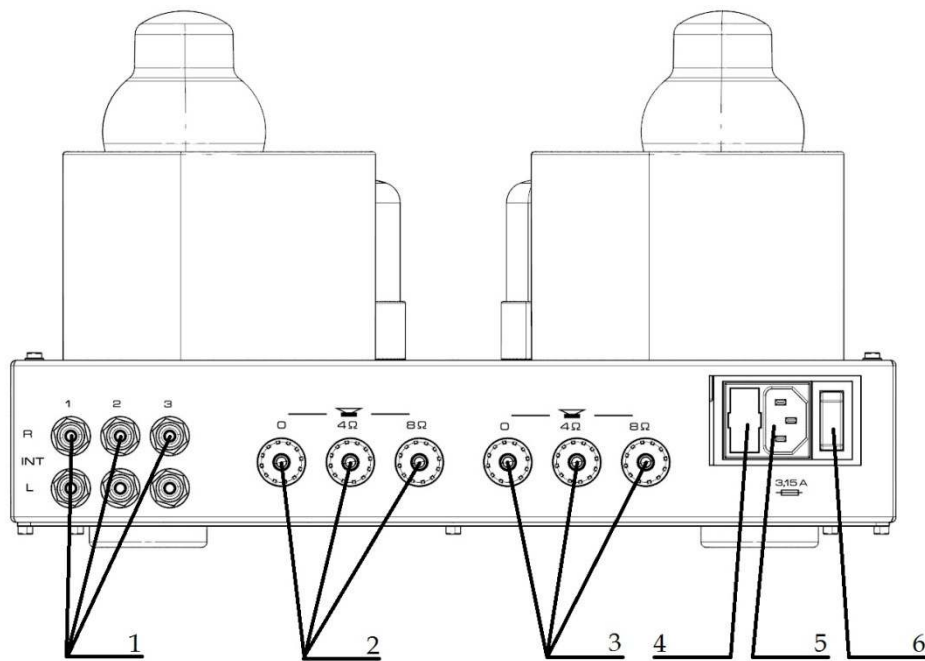

- 1) Source signal inputs
- 2) Speaker outputs for the right channel
- 3) Speaker outputs for the left channel
- 4) Socket for the main fuse
- 5) The IEC power supply cord socket
- 6) Mains switch



WARNING! - To avoid electrostatic shock to the components of the amplifier, please touch a grounded conductive surface before making any connections.

HOOK-UP OF THE POWER SUPPLY CORD

Make sure that the amplifier is switched off. Connect the power cord to the IEC socket on the rear panel of the amplifier.

The amplifier is designed to operate at a rated voltage of 230V/50Hz (or 115V/60Hz US and CAN models). Connecting the device to a mains network with incorrect parameters can lead to damage that is not covered by manufacturers warranty

HOOK-UP OF THE SIGNAL SOURCES

Connect the signal source to the amplifier inputs IN1, IN2 or IN3. Select the source of input signal by rotating the input selector located on the front panel of the amplifier. In order to achieve the highest sound quality, use only high-quality RCA cables. Pay attention to the proper connection and distinction of the right (R) and the left (L) channels.



WARNING! To connect a turntable, you need to use an external phono MC/MM preamplifier or a turntable with a built-in preamplifier.

HOOK-UP OF THE SPEAKERS

Check the impedance of the speaker set that you possess. Connect the speaker cable to the appropriate terminals on the rear panel of the amplifier. Depending on the impedance of the speakers that you possess, connect it to the terminal marked either 4Ω or 8Ω. If your speaker impedance is 6Ω - connect the speaker wire to the terminal 8Ω.

STANDARD and OPTIONAL EQUIPMENT _____

VACUUM TUBES PROTECTIVE CAGE(standard equipment)

The picture shows the correct positioning of the vacuum tubes protective cage.



VOLUME LEVEL REMOTE CONTROL (optional equipment)

The remote control enables remote adjustments of the volume.



HT (Pre-in) INPUT (optional equipment)

The additional HT (Pre-in) signal input makes it possible to use this amplifier as a stereo power amplifier. In order to make this possible, it is necessary that you have a separate pre-amplifier with its own volume control, or a receiver with 'Pre-out' output.



WARNING! Never directly connect sources such as a CD, DVD, BlueRay, DAC, file streamer, or similar devices to the HT (Pre-In) input. The HT input HT is specifically and exclusively designed for use with preamplifiers with adjustable output volume and with receivers which are equipped with a 'pre-out' .

FIRST POWER-UP AND GETTING STARTED _____

Make sure that all of your wiring is connected in accordance with the information as provided above on page 9 of this manual.

Select the source of signal using the rotary selector switch located on the front panel.

Set the volume control to minimum. Turn on the mains power of the Mira Ceti amplifier – the vacuum tubes shall begin to glow. Make sure that the sound source is turned on, playing, and then gradually increase the volume level by turning the potentiometer.

The correct 'Switch-ON' (start-up) sequence for the individual devices:

First the Signal Source → then the Fezz Audio Mira Ceti amplifier.

The correct 'Switch-OFF' (shutdown) sequence for the individual devices:

First the Fezz Audio Mira Ceti amplifier → and then the Signal Source.

The operation of the amplifier narrows down to adjusting the volume potentiometer VOLUME and selecting an audio signal source via rotation of the SOURCE switch.

ADJUSTMENT AND CONTROL OF THE BIAS CURRENTS _____

The amplifier is equipped with an automatic bias module and does not require any kind of adjustment.

REPLACEMENT OF VACUUM TUBES _____

In the event that a need arises to replace the vacuum tubes, either the power tubes, or the control tubes, the following guidelines must be adhered to:

- The 300b power vacuum tubes may be replaced only with the same type, or with another type, but such that is a direct equivalent.

- You can replace the 6sn7 control tubes only with the same type, or with another type, but such that is their direct equivalent.

VACUUM TUBE REPLACEMENT PROCEDURE

- 1) Disconnect the amplifier from the mains.
- 2) Remove the currently installed tubes, from the sockets. Plug in the new vacuum tubes in these sockets. Remember to use **ONLY** vacuum tubes that have previously been pre-selected and paired up in quads or pairs.
- 3) Reconnect the amplifier from the mains.

"BURNING-IN" OF THE AMPLIFIER _____

Any tube amplifier requires an initial pre-heating (or "burn-in") period, in order so that it achieves its full sonic potential. This is due to the presence of residual polarization of dielectric elements and due to a necessary stabilization of working parameters of the vacuum tubes. The stabilization of the electrical parameters of the system occurs in a natural process whilst playing music through your audio system.

A preliminary degree of pre-heating of the amplifier is reached after about 10 hours of quiet music playback. The full sonic capabilities shall stabilize and unfold within a time-span ranging from 40 to 60 hours of music reproduction at a moderate volume levels.

In the initial period of operation of the amplifier it is advisable to avoid short-term operation periods of the amplifier. Once activated, it should remain operational for a period of about 4-6 hours.

TROUBLE-SHOOTING GUIDE

If your amplifier does not work as it is supposed to, it is fairly easy to diagnose and remedy some of the common malfunctions, by following procedures as outlined in this following.

THE PROBLEM	PROBABLE REASON	THE SOLUTION
After turning the power switch to the ON position, the amplifier does not switch on	A blown fuse.	Please exchange to faulty fuse to a new one (3,15A T), within the fuse holder as depicted with index 4 on page no. 8 of this user manual.
	An improper connection of the mains cable.	Please check if the plugs of the mains cable are properly inserted into the electrical mains socket and to the socket as depicted with index 5 on page no. 8 of this user manual.
The sound produced by the amplifier is distorted. A hum or pops have appeared and are coming from one of the channels	Improper placement of the vacuum tubes in the sockets.	Switch off the amplifier. Wait until the vacuum tubes cool down. Check for proper placement of vacuum tubes in their sockets. If necessary - correct their orientation.
	One of the driver tubes (6SN7) has lost its nominal working parameters.	Switch off the amplifier. Wait until the vacuum tubes cool down. Exchange the positions of the driver tubes between channels. Turn on the amplifier. If the disturbing sounds have moved to the other channel, please send the faulty tube back to Fezz Audio, informing the company about the need for its replacement.
	One of the power tubes (300B) has lost its nominal parameters, within an amplifier that is equipped with manual bias.	Switch off the amplifier. Wait until the vacuum tubes cool down. Exchange the positions of the driver tubes between channels. Turn on the amplifier. If the disturbing sounds have moved to the other channel, please send the faulty tube back to Fezz Audio, informing the company about the need for its replacement.

If you have verified the aforementioned situations, and your problem still persists, please contact our service department (info@fezzaudio.com)

TECHNICAL DATA

Type:	Integrated stereo power amplifier
Model:	Mira Ceti
Output power:	2x 8W
Circuit architecture:	Single Ended class A
Output Impedance :	4Ω / 8Ω
Input connectors:	3x RCA
THD distortion:	< 0,4%
Frequency response:	20Hz - 45kHz (-3dB)
Power consumption:	80W
Mains fuse:	3,15A T / delayed
Weight:	14 kg
Dimensions:	340 x 360 x 215mm
Tube types:	2x300b (or sim.) / 2x 6sn7 (or sim.)

LIMITED WARRANTY CONDITIONS _____

The manufacturer, the company Fezz Audio warrants that this Mira Ceti amplifier is free from defects in materials and in workmanship.

This warranty is valid for a period of 24 months from the date of purchase.

During the warranty period, any defects will be repaired free of charge, after showing the proof of purchase (receipt), in its original form.

You are responsible for transporting the equipment from the place of use to the dealer, distributor, national or international.

The warranty applies only to the original purchaser. The warranty is non-transferrable to subsequent owners.

This guarantee is subject to the following limitations and will be cancelled, void and null in case of:

- Use of the product that is not in accordance with this Users Guide
- Mechanical damage by the user
- Damage caused by electrical discharges (storms)
- Breach of guarantee seals, unauthorized use, adjustments or modifications
- Carelessness or damage resulting from improper transportation

The company Fezz Audio reserves the right to amend the designs of its products and their specifications without prior notice to the previous buyers.

Fezz Audio

ul. Mazowiecka 20

16-001 Księżyno / Poland

www.fezzaudio.com